

Traffic Signals (8"/12" PC/AL)

Four screw visor attachment
(threaded brass inserts on
poly doors)

"Tab" Visor



8" Al Signal

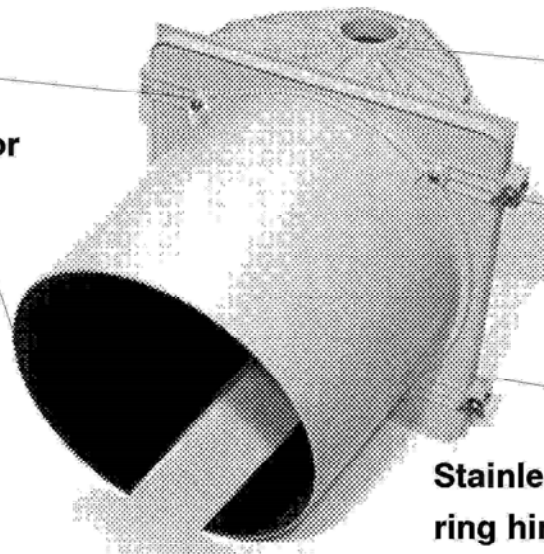

Self draining heavily
ribbed end sections
with integral shurlock

Captive wing nut
style door latch
assemblies

Backplate mounting
holes (4 per section)

Stainless steel reflector
ring hinge pins

Door Gasket

One piece molded EPDM lens
gasket (Silicone available)

Alzak Reflector

Stainless Steel lens tabs;
(threaded brass inserts on
poly doors)

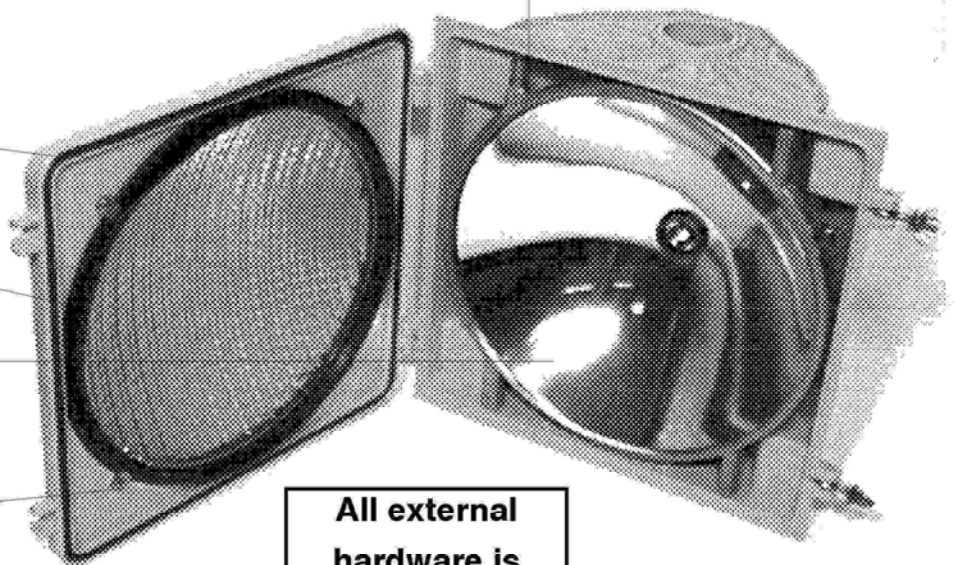

All external
hardware is
stainless steel

Reinforcing fins in poly head

Reflector Gasket

Fully insulated quick connect
socket wire terminals

Color coded socket wires

Rotatable high temperature
phenolic socket with lamp grip
and gasket

Aluminum reflector ring

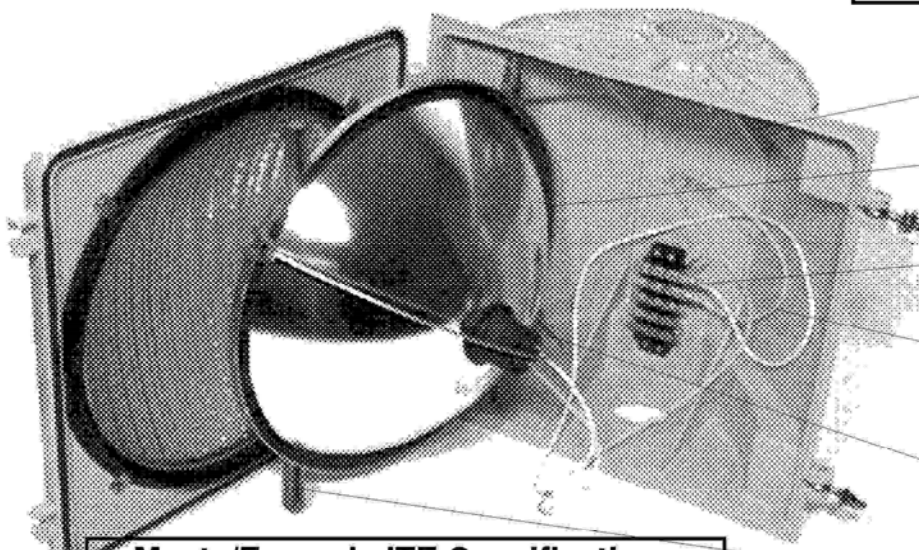

Meets/Exceeds ITE Specifications

Traffic Signal Housing

8" Diameter
12" Diameter
Aluminum
Polycarbonate

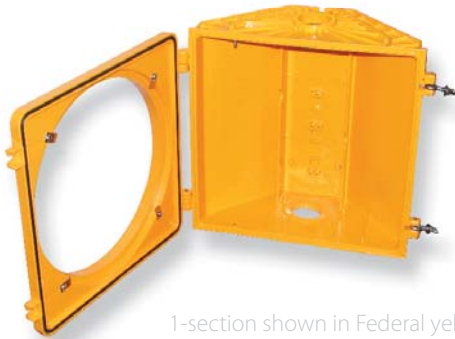

1-section shown in Federal yellow



3-section shown in Federal yellow

Cabinets
Controllers
Signals
Signs
Software
Specialty

Overview

McCain's Traffic Signal Housings, available in eight and twelve inch varieties, provide a durable and low-maintenance housing for standard LED modules as well as McCain incandescent optical assemblies. Manufactured from polycarbonate or aluminum, the housings are compliant with multiple agency standards including the Institute of Transportation Engineers (ITE), Caltrans, and most state Departments of Transportation (DOTs). An industry leader in signal manufacturing and supply, McCain offers an extensive range of materials, configurations, and accessories, including backplates, visors, and signal assemblies, to meet your traffic signal requirements.

Benefits

- Modular design promotes flexible configuration options: one to five sections, vertical, horizontal, and doghouse (5-section cluster)
- Fabricated from aluminum or polycarbonate with 10% fiberglass reinforcement (available without fiberglass reinforcement)
- 8" or 12" diameter
- Weathertight doors
- Custom hardware and terminal block location available

Product Description

The McCain Traffic Signal Housings are modular in design, allowing a multitude of signal housing configurations for standard LEDs as well as McCain incandescent optical assemblies.

Available in polycarbonate and aluminum, each section is injection molded or cast in one piece. Reinforcement ribs and serrated ports, both top and bottom, provide strength and positive locking with other sections and mounting hardware. Positive latching of doors is achieved with stainless steel eyebolts and wing nut assemblies, and the doors feature four metal threaded inserts for visor attachment. A positive seal is assured with an E.P.D.M. rubber gasket creating a moisture-free and dust-tight atmosphere.

Traffic Signal Housings are compatible with McCain backplates and visors, available in both aluminum and ABS. The top and bottom ports allow installation into many framework mounting assemblies.

Traffic Signal Housing

Front

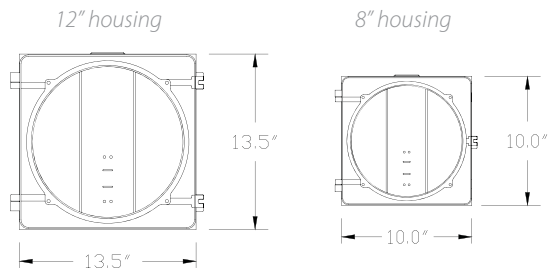

Top

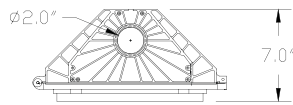

Side

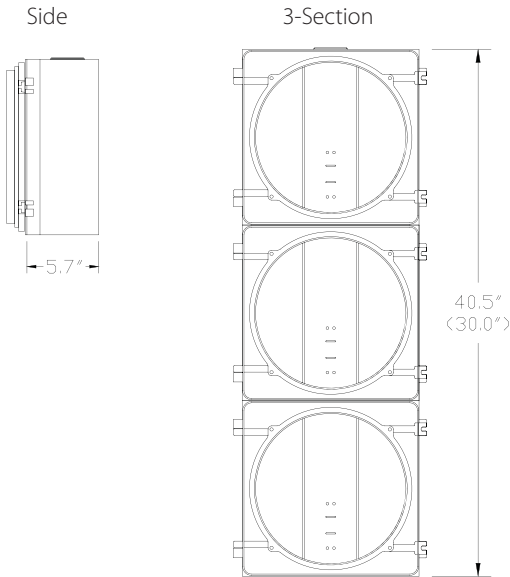

Dimensions are approximate and may vary.

3-section 12" housing shown as an example configuration. 3-section 8" housing height dimensions is listed in parentheses.

Depth for the 8" and 12" housings are approximately the same.

Minor differences between the 8" and 12" may not be shown.

Typical configurations

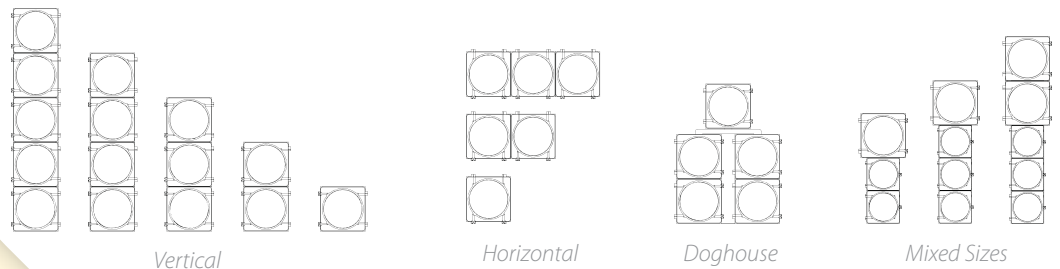

Standard Features

- Modular sections, one-piece, injection molded or cast
- 72-tooth serrated boss and reinforcing ribs, top and bottom
- Brass threaded inserts for visor attachment (4)
- Housings have a cast boss for mounting a 5 or 6-position terminal block; one side of terminal block with fast-on terminals, the other side with screw terminals
- The words red, amber, and green are cast next to each boss to identify light source lead wires
- 5 or 6-position terminal block installed in center section (1) (alternate mounting is available)
- Stainless steel door roll pins and eye bolt/wing nut assemblies
- Integral lugs on the housing and doors with stainless steel roll pins provide effective door hinges
- Weathertight E.P.D.M. rubber door gasket
- Aluminum and polycarbonate, and 8" and 12" housings can be mixed in one signal head

General Specifications

| | |
|------------------|---|
| Dimensions: | 8": 10.0" H x 10.0" W x 7.0" D |
| (1-section) | 12": 13.5" H x 13.5" W x 7.0" D |
| Material: | Polycarbonate: Ultraviolet and heat stabilized, flame retardant, permanently colored, 10% fiberglass reinforcement Aluminum: Type 360, reduced corrosion, increased powder coat adhesion |
| Finish(es): | Polycarbonate: Colored resins integral to housing Aluminum: Powder coated |
| Color(s): | Federal yellow, signal green, black, or custom colors |
| Mounting: | 2.0" hole top and bottom fits 1.5" NPT fittings |
| Environmental: | Operating temperature: -37°C to +74°C Humidity: 0 to 95% (non-condensing) |
| Shipping Weight: | Polycarbonate: 8" - 2.1 lbs 12" - 4.2 lbs (empty, 1-section) Aluminum: 8" - 4.0 lbs 12" - 7.8 lbs |

Options

- Fiberglass-free polycarbonate
- Location, quantity, and type of terminal blocks
- Door mounting hardware: Push pin (removable) or roll pin (permanent)
- Visors
- Backplates
- Mounting: Various framework, orientation, and configurations
- Light Source: LED or incandescent
- High-performance (highly directional) signal version

To learn more about McCain's Integrated Traffic Solutions, please contact info@mccain-inc.com or call (760) 727-8100



2365 OAK RIDGE WAY // VISTA, CALIFORNIA 92081 // USA // WWW.MCCAIN-INC.COM

© 2009 McCain Inc. Updated 01/27/09. McCain reserves the right to change product specifications without notice. For the most up-to-date information, please contact McCain.